

Role of Horizontal Backfill Passive Pressure on the Stability of Masonry Vaults

P. Gelfi

Dipartimento di Ingegneria Civile, Università di Brescia, Brescia, Italy

Abstract

Equilibrium and mechanism methods are the most attractive tools for the assessment of the safety of masonry arches and vaults. In the classical implementation of these methods the backfill is taken into account as a mere vertical surcharge, ignoring the horizontal passive pressures which can be mobilized when the arch sways into the backfill. This approach is generally on the safe side, but often does not allow to assess the stability of existing masonry arches, particularly in the case of asymmetrical live loads.

In order to quantify the contribution of the horizontal pressures exerted by the fill, an experimental investigation was conducted on a small-scale model. The physical model was designed in such a way that it can resist the loads only due to the lateral contribution of the fill. In the theoretical interpretation of the experimental data, a classical linear distribution for the horizontal stresses in the fill was assumed, while the geometrical non-linearity of the model was taken into account. A good agreement was obtained between the experimental and theoretical data. The importance to consider the horizontal pressures exerted by the fill is illustrated by an example of assessment of a typical barrel vault subjected to a sustained asymmetrical live load.

Keywords: Masonry Vault, Barrel Vault, Stability, Safety, Backfill Pressure, Model Testing

Zum Einfluss des passiven Druckes aus der Hinterfüllung auf die Stabilität von Gewölben aus Mauerwerk

Zusammenfassung

Gleichgewichts- und mechanistische Methoden sind sehr attraktive Hilfsmittel, wenn es darum geht, die Sicherheit von Bögen und Gewölben aus Mauerwerk zu bestimmen. Die klassischen Methoden berücksichtigen die Hinterfüllung lediglich als eine vertikale Auflast; sie vernachlässigen aber den passiven horizontalen Druck, der entsteht, wenn der Bogen in die Hinterfüllung gedrückt wird. Im allgemeinen ist dieser Ansatz auf der sicheren Seite. Die Stabilität bestehender Bögen aus Mauerwerk kann jedoch so in vielen Fällen nicht wirklichkeitsnah abgeschätzt werden. Dies trifft besonders zu, wenn Nutzlasten asymmetrisch einwirken.

Um den Beitrag des horizontalen Druckes aus der Hinterfüllung quantitativ angeben zu können, wurden Versuche an einem Modell in kleinem Maßstab durchgeführt. Das physikalische Modell war so geplant, dass die Lasten nur bei Querdruck aus der Hinterfüllung aufgenommen werden konnten. Bei der Interpretation der Versuchsergebnisse wurde eine klassische lineare Verteilung der Spannungen in der Hinterfüllung angenommen, dagegen wurde die geometrische Nichtlinearität des Modells berücksichtigt. Eine gute Übereinstimmung zwischen den experimentellen Daten und den theoretischen Ergebnissen konnte festgestellt werden. An Hand eines Beispiels wird gezeigt, wie wichtig es ist, den horizontalen Druck aus der Hinterfüllung zu berücksichtigen. Im Beispiel wird ein typisches Tonnengewölbe untersucht, auf das eine asymmetrische Nutzlast einwirkt.

Stichwörter: Gewölbe aus Mauerwerk, Tonnengewölbe, Stabilität, Sicherheit, Druck aus Hinterfüllung, Modellversuch.

1 Introduction

A growing interest in the preservation of heritage and historic structures has created a need for efficient methods for the analysis of arches and vaults that are the principal components of these structures. In a recent review of the analysis methods of masonry arches and vaults, Boothby [1] highlights the usefulness of the plasticity methods to the understanding of the behaviour of masonry arches and vaults. The application of the ideas of plasticity theory to the study of masonry structures starts with Heyman's works [2]. The "safe theorem" can be stated as follows: a masonry arch is safe if a line of thrust, in equilibrium with external loads and lying wholly within the thickness, can be found and the corresponding stresses are sufficiently low. Traditionally the eccentricity of the line of thrust was limited to one sixth (Méry) or to one fourth (Heyman) of the ring thickness. Failure of an arch, if ties or supporting walls are adequate, is mainly related to its shape, not to crushing of the material [3].

In the usually adopted plasticity methods the backfill is regarded as a mere dead load, relevant to the stability of the arch only because it contributes to centre the thrust line. As a consequence, safety of the arch is difficult to assess when live loads are relevant with respect to dead loads and are not uniformly distributed over the entire span. In fact, when the arch is not uniformly loaded, it tends to deform toward the backfill, which reacts opposing its passive earth pressure resistance (Fig. 1).

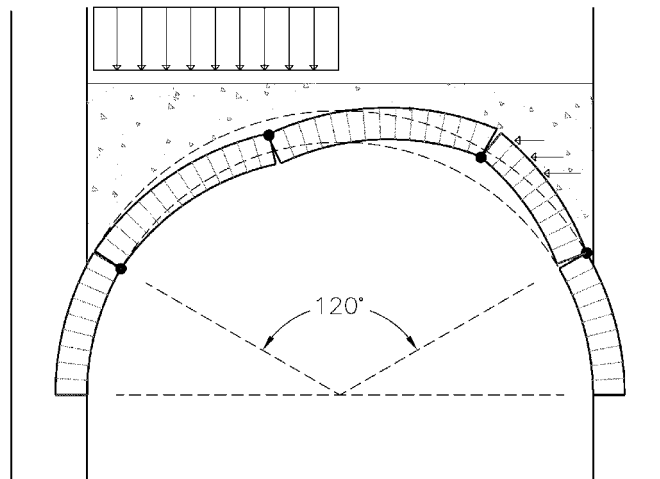

Figure 1: Horizontal passive pressures exerted on the ring

The structural role of the backfill is studied by Fairfield and Ponniah [4], particularly with respect to its ability to distribute the action of concentrated loads in arch bridges. Harvey [5] states: “The analyst must select a value of pressure coefficient to be used ... between the ‘at rest’ and ‘passive’ coefficients ... conservative estimates may be made between (say) 0.5 and 2”. Giuriani, Gubana and Arengi [6] have studied the use of light coherent fills and spandrels to limit the vault bending and Giuriani and Gubana [7] have analysed the role of the extrados ties.

The structural role of the backfill to counteract the tendency of the arch to bend upside, opposing its passive pressure resistance, is not much studied. In the present paper the problem is faced experimentally on a physical model of circular arch (Fig. 2, 3), with five hinges (doubly hypostatic), so that it can resist the loads only due to the fill passive resistance contribution. A concentrated load is applied at crown, directly to the arch to avoid any contribution due to the diffusion through the fill.

Experimental results are interpreted through a classical theoretical model, suitable for design practice. An assessment example shows the importance to account for the horizontal passive pressures to assess the stability of a typical barrel vault subjected to a sustained asymmetrical load. The example shows that in many cases expensive and intrusive rehabilitation intervention can be avoided.



Figure 2: The physical model of an arch

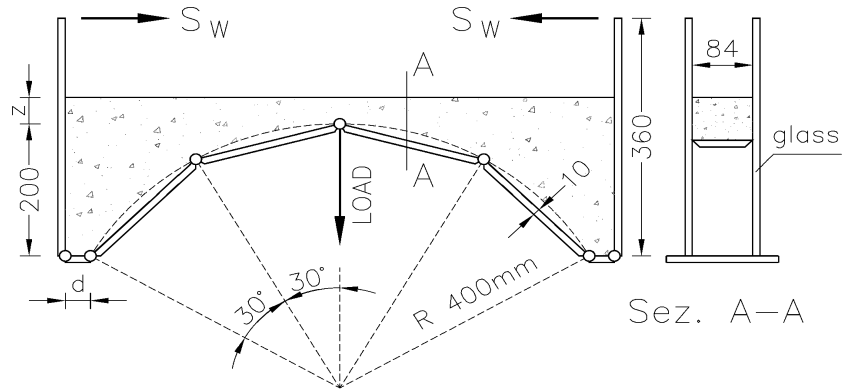

Figure 3: Geometry of the physical model shown in Fig. 2

2 Experimental Apparatus

The arch experimental model is illustrated in Fig. 2. It is composed of four wood segments mutually hinged. The model is hypostatic, so that the role of the passive pressures on the arch stability is essential. Dimensions (Fig. 3) correspond, in scale 1:5, to a semicircular arch of 4 m diameter (Fig. 4).

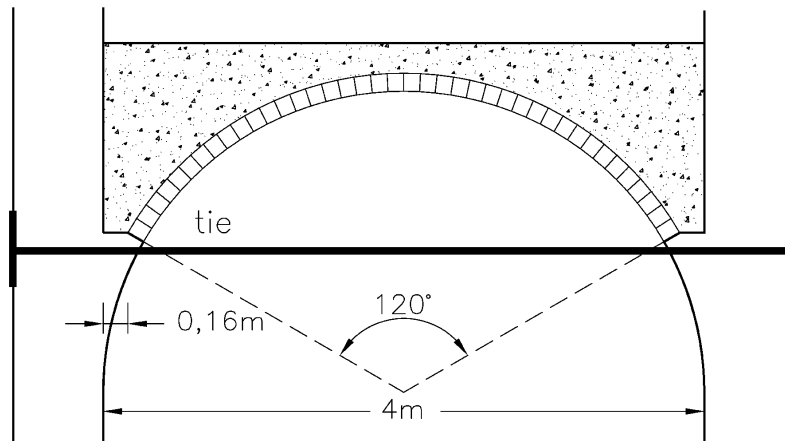

Figure 4: A typical semicircular barrel vault

The arch model is inserted in a container with glass walls to allow observation of the fill deformations and of the failure mechanism. Friction between fill material and glass has a negligible value, since the friction angle is about 5° . Plastic strips are positioned to prevent the penetration of sand between the arch and the glass walls and hinges are protected and lubricated.

Lateral walls are positioned at a distance $d=35$ mm, which represents in scale the typical distance of the walls at springings for a semicircular arch with 4m diameter and 12 cm thickness (Fig. 4). Tests with $d=165$ mm were also carried out to evaluate the influence of the wall distance.

To measure the fill displacements, a photogrammetric procedure was adopted. To make visible in the subsequent tokens specific points of the fill, pencil red leads, 0.5 mm thick, were inserted, during the sand deposition, perpendicular to the glass wall. To enhance the contrast in the photograms, the fill was coloured with black Indian ink (Fig. 5). On the front glass wall white targets, utilised as points of support

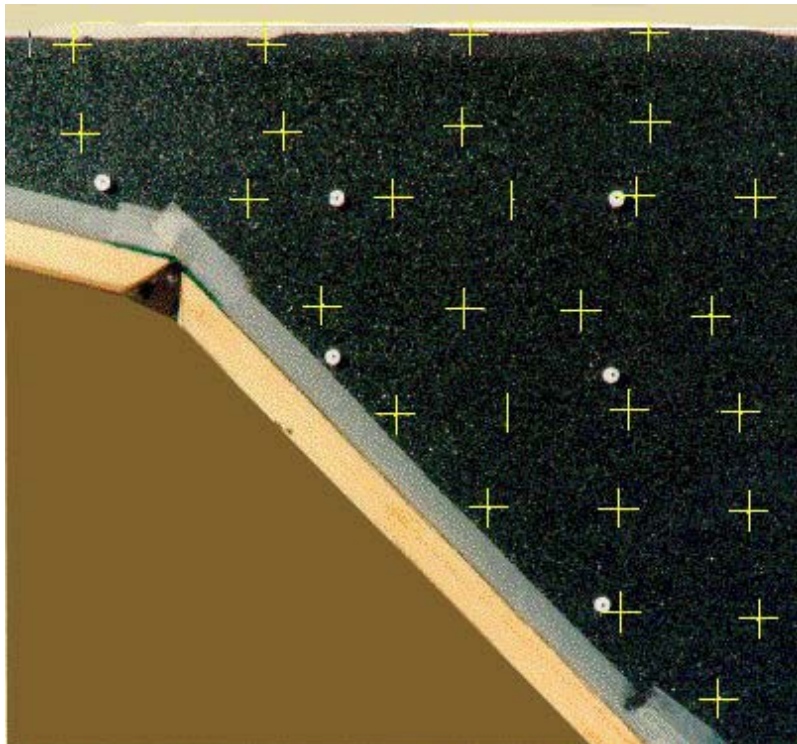

Figure 5: A photogram with all measure points marked by a cross

to rectify the tokens, were applied. The estimated r.m.s. error in the displacement measure is 0.07 mm.

The backfill material is sand with a maximum grain size of 0.8 mm, unit weight $\gamma=13.14 \text{ kN/m}^3$, angle of friction $\varphi = 32^\circ$ (measured by direct shear tests). Tests are conducted for backfill thickness at crown $z=1 \text{ cm}$ and $z=4 \text{ cm}$.

For the test, the arch model is inserted in the container and fixed to the initial position with temporary supports. Sand is then deposited, without any compaction, and its total weight is measured. After the deposition, before the support removal, the load V is applied at crown up to the value V_E that equilibrates the weight of the fill. V_E varies between 2.0 N (for backfill thickness at crown $z=40 \text{ mm}$) and 4.4 N (for $z=10 \text{ mm}$). A load increment of 0.5 N is applied at each step. Given the low values of the applied loads, also the spring reaction (0.8 N) of the mechanical gauge, that measures the displacement at crown, is computed in the value of load V . During two of the tests, the lateral walls were maintained vertical through an equilibrating force S_W applied at a height of 360 mm from the hinge (Fig. 3), measuring in this way the horizontal thrust exerted by the fill.

3 Experimental Results and Interpretation

Fig. 6 shows the vectors which represent, amplified 20 times, the fill displacements up to the second-last load step (first vector) and to the last (onset of failure) step (second vector). The motion of the portion of fill on the right side appears to be a rotation around the lower hinge, with a tendency to turn upside at the onset of failure, whilst the portion of fill near the crown moves down.

In Fig. 7a) and 7b) the experimental load-displacement curves, for backfill thickness $z=10 \text{ mm}$ and $z=40 \text{ mm}$, are plotted. The curves for lateral walls distance $d=165 \text{ mm}$ are drawn in dashed lines. Theoretical curves, obtained through the procedure explained in paragraph 4, are also plotted. The value of the equilibrium load V_E , calculated ignoring the horizontal passive pressures, is indicated.

The diagrams show rather scattered values of the failure load, depending on the compaction degree. The dependence on the lateral walls distance d seems to be negligible. The collapse load values, considerably higher than the equilibrium loads V_E , indicate the importance of the passive pressure action in the arch stability. The fit between theoretical and experimental data is satisfactory.

Fig. 8 shows the results of the two tests carried out with the measurement of the horizontal thrust exerted by the fill on the lateral walls.

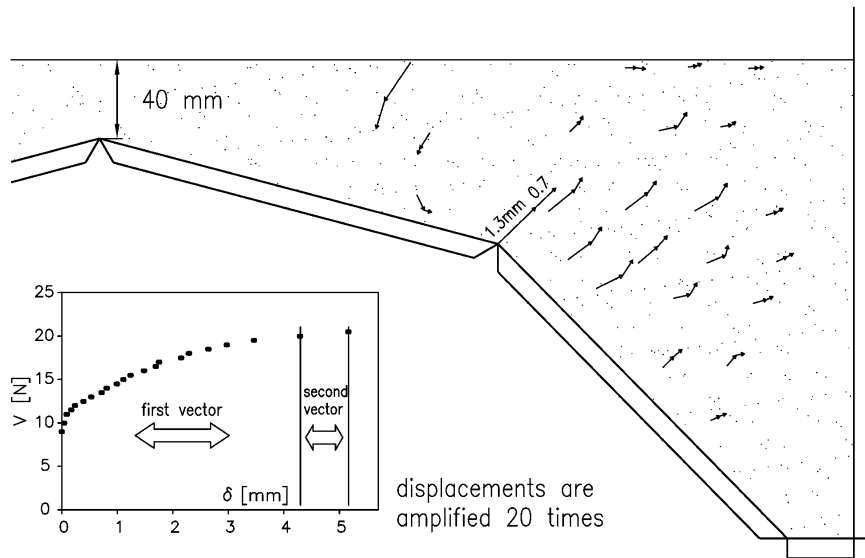

Figure 6: Fill displacements at the onset of failure

4 Theoretical Interpretation of the Experimental Results

Experimental results can be numerically modeled starting from the classical assumption that the magnitude of the horizontal backfill pressure is proportional to the vertical self-weight pressure exerted by the backfill material, i.e. the horizontal pressure at depth h is given by:

$$\sigma = k_p \gamma h \quad (1)$$

where the passive earth pressure coefficient k_p varies with the compaction effect induced by the movement of segment AB (Fig. 9a) toward the vertical wall and is therefore function of angle ϑ .

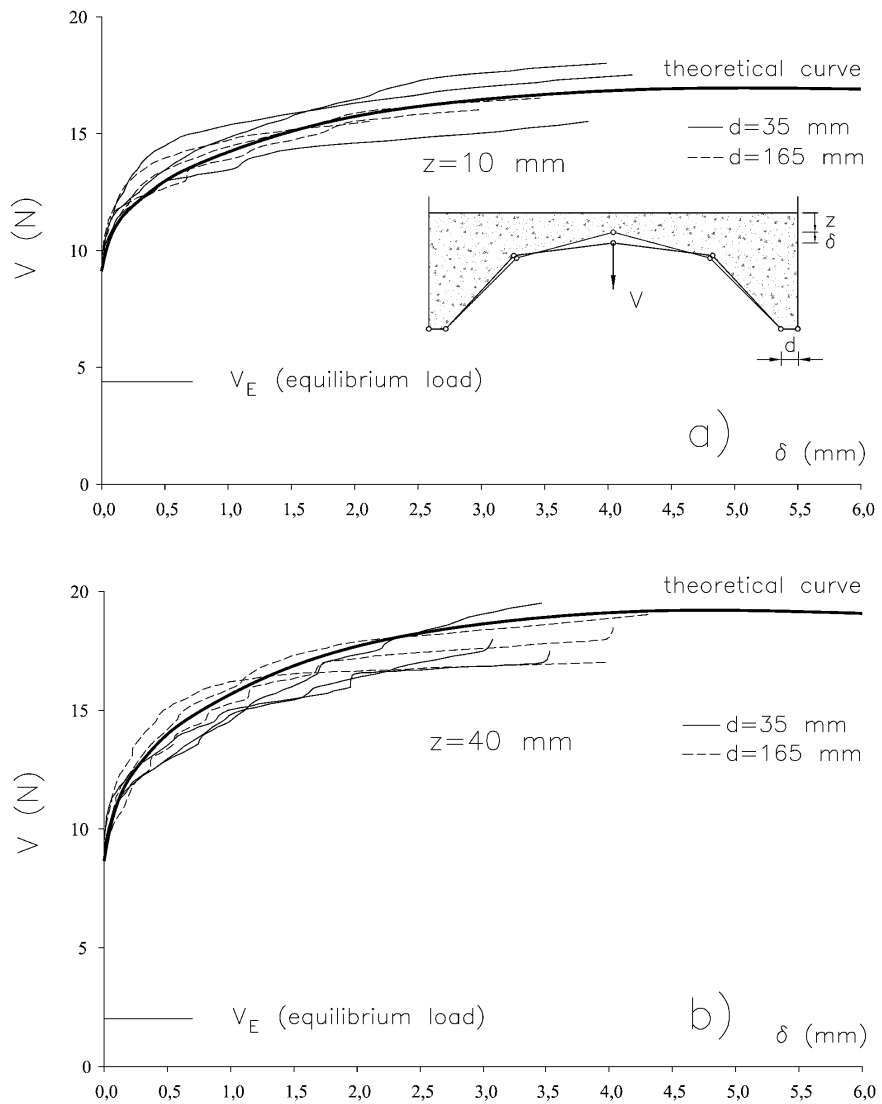

Figure 7: Force V experimental and theoretical diagrams: (a) for $z = 10$ mm and (b) for $z = 40$ mm

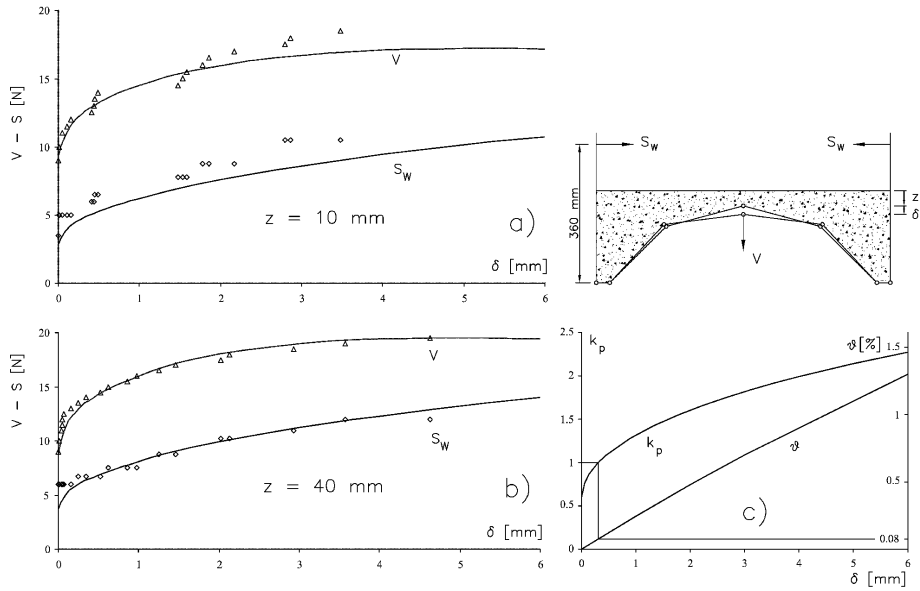

Figure 8: Theoretical and experimental values of thrust S_M and force V

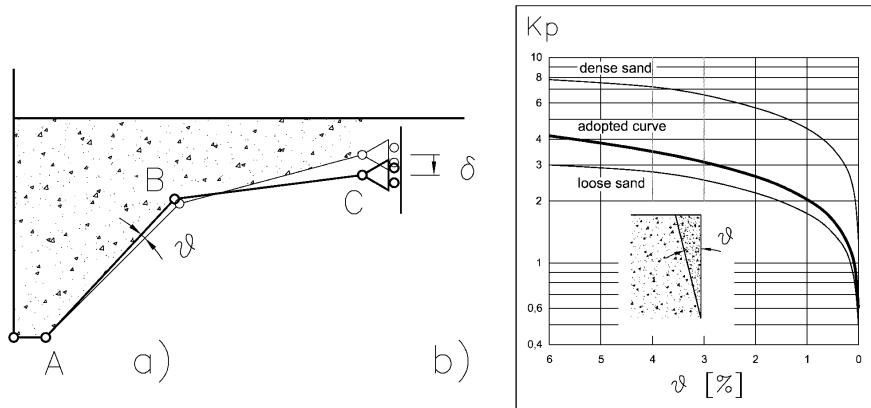

Figure 9: Relation between coefficient k_p and rotation ϑ

For the relation k_p - ϑ , reference is made to the classical diagrams of Fig. 9b) taken from [8], adopting the curve, plotted in bold and expressed by equation (2):

$$k_p = k_0 + 14.5\sqrt{\vartheta} = 0.6 + 14.5\sqrt{\vartheta} \quad (2)$$

where $k_0 = 0.6$ is a suitable value of the coefficient of earth pressure at rest.

Since angle ϑ is geometrically related to displacement δ (the relation, as shown in Fig. 8 c), is quite linear in the range of small displacements), it is easy to compute, as functions of δ , the measured forces S_W and V , imposing equilibrium around hinges A and B (Fig. 10):

$$V/2(x_C - x_A) - H(y_C - y_A) + P_{AB}(x_{P_{AB}} - x_A) + P_{BC}(x_{P_{BC}} - x_A) + M_{SA} = 0 \quad (3)$$

$$V/2(x_C - x_B) - H(y_C - y_B) + P_{BC}(x_{P_{BC}} - x_B) + M_{SB} = 0 \quad (4)$$

$$\text{where: } M_{SA} = S_{AB}(y_{S_{AB}} - y_A) + S_{BC}(y_{S_{BC}} - y_A)$$

$$M_{SB} = S_{BC}(y_{S_{BC}} - y_B)$$

$$S_{AB} = (\sigma_A + \sigma_B)(y_B - y_A)/2$$

$$S_{BC} = (\sigma_B + \sigma_C)(y_C - y_B)/2$$

M_{SA} and M_{SB} are the contributions to equilibrium given by the backfill passive resistance.

In Fig. 8 the values of V (vertical force at crown) and S_W (horizontal force on the wall calculated at the point where it was measured during the test) are plotted, superimposed to experimental data, both in the case of 10 mm and of 40 mm backfill thickness. Theoretical and experimental values are in good agreement, especially in the case of 40 mm backfill thickness.

Theoretical curves are plotted up to a value $\delta = 6$ mm to show that the numerical model is able to predict also the collapse load, whose theoretical value is reached for $\delta \cong 5.5$ mm, with $k_p \cong 2.2$.

5 Example for the Assessment of Safety of Arches

The importance to consider the horizontal pressures exerted by the fill is highlighted by the example of a typical barrel vault, subjected to a sustained asymmetrical live load, as illustrated in Fig. 11.

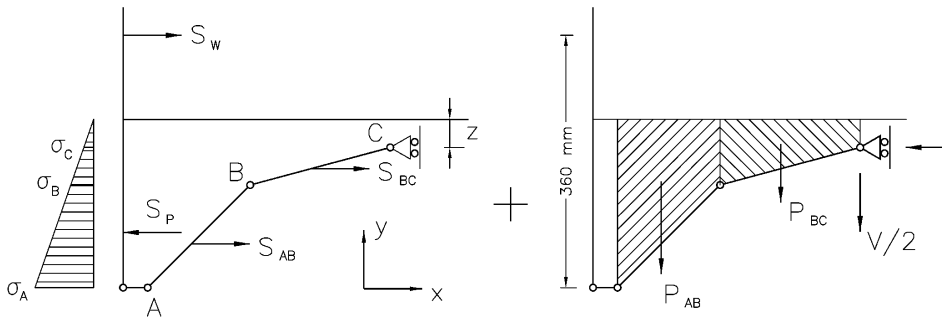

Figure 10: Scheme of the forces acting on the model.

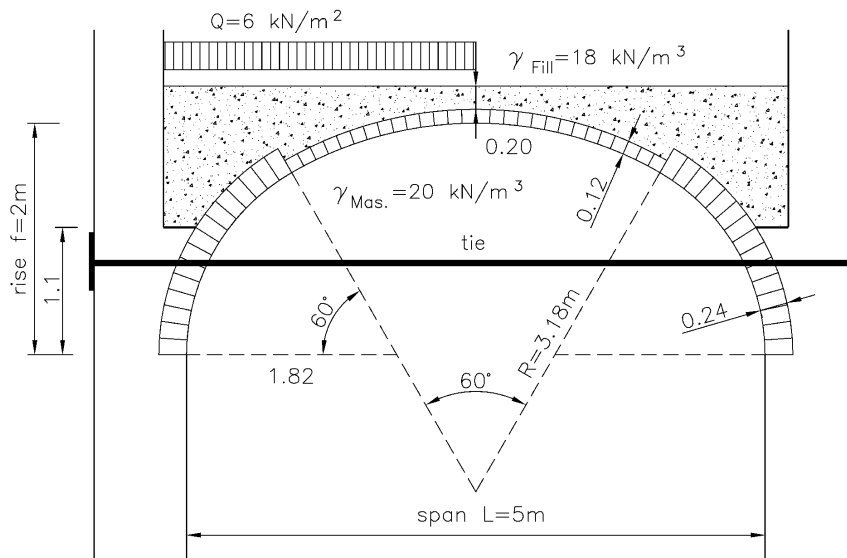

Figure 11: Example of the polycentric barrel vault

The shape of the intrados is polycentric, and the radius of the central segment is given by the relation:

$$R = \frac{L \sin 60^\circ - f}{2 \cdot \sin 60^\circ - 1} \quad (5)$$

The arch has a span of 5m and a rise of 2m. The relatively high rise will enhance the influence of horizontal pressures. The ring depth is 12 cm (width of a brick) in the central segment and 24 cm (height of a brick) in the lateral segments towards the springings. Material densities are 20 kN/m^3 for the masonry and 18 kN/m^3 for the fill. The covering at crown is 20 cm. Fig. 11 shows also the tie that is usually positioned at springers.

To assess the arch safety the lower bound theorem is used. Using a computer program implemented by the author [9], the optimal thrust line is sought. Each voussoir is subjected to the self-weight P_M and to the weights of the overhanging backfill P_F and live load P_Q columns (Fig. 12). Three hinges are inserted (at springers and crown) to make the arch isostatic and to draw the thrust line. The position of the hinges are iteratively varied to minimize the eccentricity of the thrust line or the value of the stresses. To improve the solution, the horizontal passive pressures are introduced: on the voussoirs that tend to bend towards the fill the horizontal forces $S = k_p P_F \tan \alpha$ are applied (Fig. 12).

Following the ultimate limit states approach, partial factors for actions and resistances must be applied. Since the dead load effect is favourable as it tends to centre the thrust line, a partial factor value 0.9 may be applied to the material densities. For

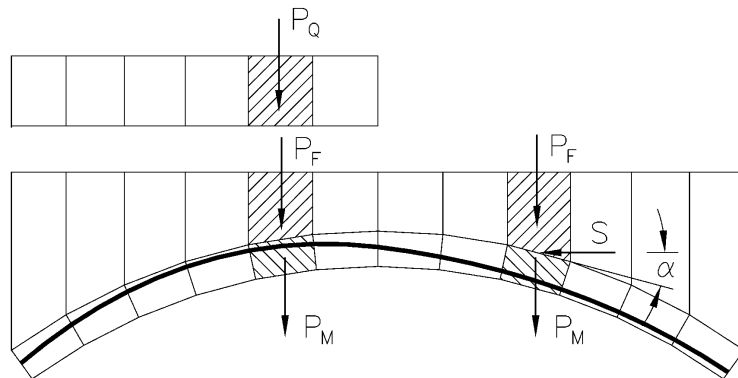

Figure 12: Forces acting on the voussoirs

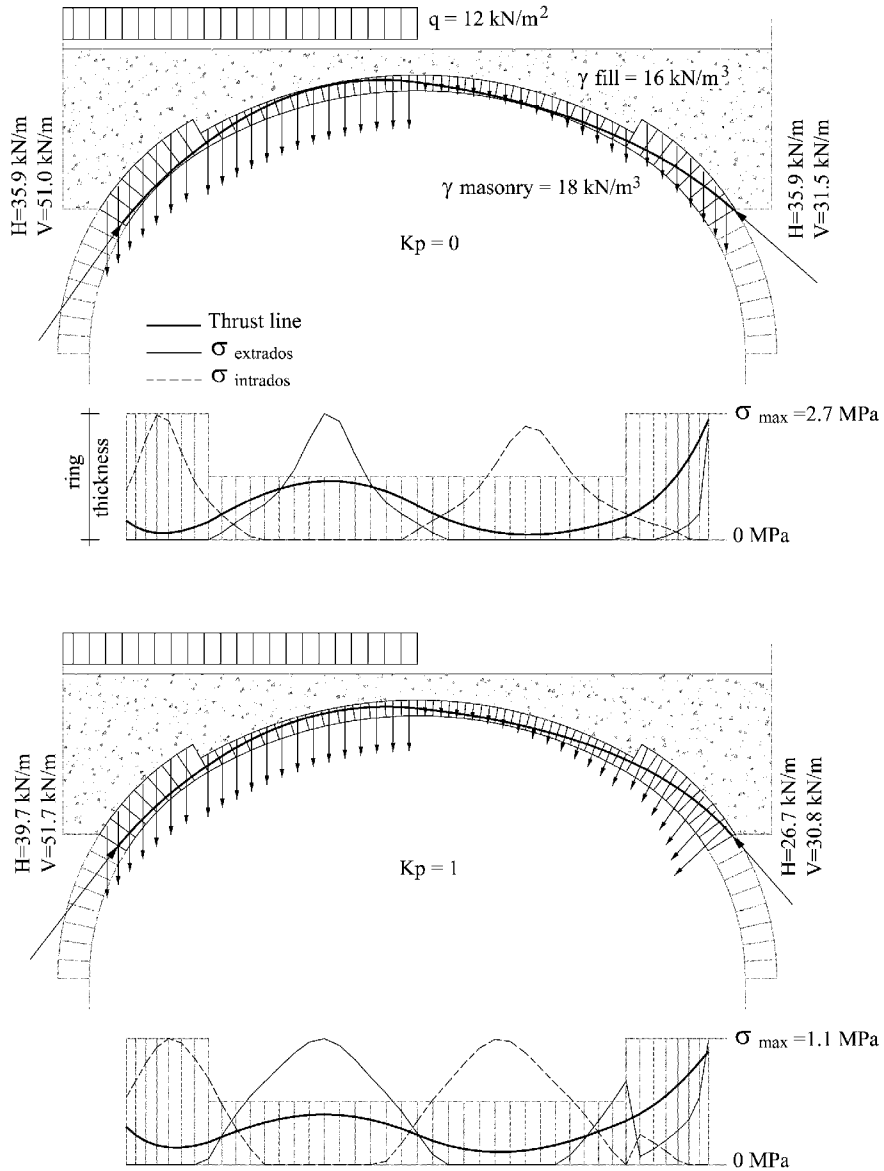

Figure 13: Thrust lines and stress diagrams.

the live load a partial factor greater than usual (say 2.0) is suggested to allow also for uncertainties in the arch geometry.

In Fig. 13 the results of the calculus are reported both ignoring (upper part) and considering (lower part) the action of passive pressures. For the pressure coefficient a reasonable and conservative value $k_p = 1$ is assumed, that would be achieved after small movements of the arch towards the fill. Fig. 8c) shows that a small rotation $\vartheta = 0.08\%$, that is a small movement of about 1.6 mm at a distance of 2 m from the springing, is required to achieve this value of the coefficient of passive pressure. Moreover a greater value does not improve significantly the solution. To better represent the position of the thrust line within the ring thickness, the arch profile is also reproduced with the thickness magnified four times. The diagrams of the maximum stresses in each section at extrados and intrados are also plotted and the values of the horizontal (H) and vertical (V) components of the thrust at springers are indicated.

The introduction of the horizontal passive pressures leads to a more centered line of thrust, in equilibrium with applied loads, and to a significant reduction of the maximum compressive stresses from 2.7 to 1.1 Mpa. This value, calculated considering an elastic distribution, reduces to 0.82 Mpa if a plastic distribution is assumed and can be accepted as design value also for a weak lime mortar. The horizontal thrust increases slightly (from $H = 35.9$ to $H = 39.7$ kN/m) at left springer, while it diminishes at right: the difference is the resultant of the horizontal pressures.

The introduction of the horizontal passive pressures acting on the ring implies the necessity to assess the equilibrium of the lateral walls. The maximum value of the pressure acting on the wall is (Fig. 14):

$$q_0 = 1 \cdot 16 \cdot 1.22 = 19.5 \text{ kN/m}^2$$

Therefore the overturning moment is equal to:

$$M_o = 4.84 \text{ kNm/m}$$

A 42 cm thickness is enough for a wall with a height of 4,5 m and a masonry design density of 18 kN/m^3 to satisfy the overturning check with an additional 1,5 safety factor. In historical buildings wall thickness is normally at least 60 cm, as drawn in scale in figs. 11 and 14.

The safety check of the walls below the vault springers does not vary significantly, due to the horizontal passive pressures, since the increase of the horizontal thrust is practically negligible, as mentioned above.

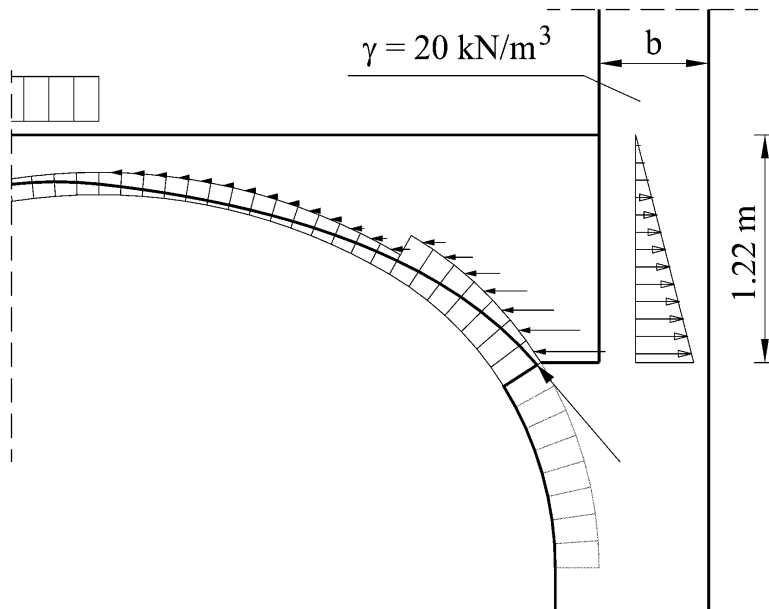

Figure 14: Horizontal pressures on lateral wall

6 Concluding Remarks

The experimental results, obtained from the test on the physical model, show the significance of the horizontal passive pressures in the arch stability. These results can be interpreted with a simple theoretical model, suitable for design practice, assuming the classical linear distribution of the horizontal pressures.

The assessment example shows that the introduction of the horizontal pressures allows to assess the safety of arches and vaults also in cases in which the classical approach would fail (as in presence of sustained asymmetrical live loads). As a consequence, expensive and invasive rehabilitation interventions could be often avoided. From the point of view of restoration, the best intervention is often no intervention.

The values of the coefficient of passive pressure k_p , to be used to optimize the position of the thrust line, are generally not much greater than the values of the coefficient of earth pressure at rest, and therefore do not imply dangerous deformations of the structure.

References

1. T. E Boothby, *Analysis of masonry arches and vaults*. Prog. Struct. Engng Mater. **3**, 246-256, (2001).
2. J. Heyman, *The stone skeleton*, International Journal of Solids and Structures **2**, 249-279, (1966).
3. P. Clemente, A. Occhiuzzi and A. Raithel, *Limit behavior of stone arch bridges*, Journal of Structural Engineering, ASCE **121**(7), 1045-1050, (1995).
4. C. A. Fairfield and D. A. Ponniah, *Model tests to determine the effect of fill on buried arches*, in Proc. Instn Civ. Engrs Structs & Bldgs **104**, (1994).
5. W. J. Harvey, *Application of the mechanism analysis to masonry arches*, The Structural Engineer **66** (5), 77-84, (1988).
6. E. Giuriani, A. Gubana and A. Arengi, *Backfill and spandrels to limit the vault bending*, in Proc. Stremah99, Eds. C.A. Brebbia, W. Jäger, WIT Press: Southampton, Boston, 738-748, (1999).
7. E. Giuriani and A. Gubana, *Extradados ties for structural restoration of vaults*, in Proc. Stremah95, Crete, Greece, Eds. C. A. Brebbia, B. Leftheris, 419-430, (1995).
8. Navfac, *Design Manual*, GM7, U.S. Naval Publ. and Forms Center, Philadelphia, (1971).
9. P. Gelfi, *Arco.exe*, Computer program downloadable in Internet: <http://civ-serv.ing.unibs.it/utenti/gelfi/arco.htm>.



Piero Gelfi is Assistant Professor at the Civil Engng. Dept. of the University of Brescia, Italy, where he teaches Theory and Design of Steel Structures. His research interests include structural rehabilitation, behaviour of r.c. structures, design of semi-rigid steel joints.